

Transient Voltage
Surge Suppressors By:

AC Distribution Panel Unit

Model LA-ST180

Dedicated Protection Components And Circuitry For Each Mode



"Power Quality is Our Only Business"

P.O. Box 330607
Ft. Worth, TX 76163
Phone: 817.483.8497
Fax: 817.572.2242
www.sinetamer.com

The SineTamer® LA series of units blends outstanding high-energy "impulse" suppression with excellent "ring-wave" transient protection. This durable device is intended for general purpose and sensitive/critical load applications. The LA-ST180 is typically installed at service entrances up to 1800 amps, distribution and sub-distribution panels. Compact size and non-metallic enclosure design also allow it to be installed directly inside electrical panels and individual equipment disconnects. The internal installation provides the absolute shortest possible lead length and optimum performance.

This economical device has features that are not available in devices costing many times its price. Its compact size makes installation a breeze. **Maintenance Free** operation and **20 Year Unlimited Free Replacement Warranty** provide peace of mind.

Standard unit is Type 2 10kA UL Nominal Discharge Current; Optional Type 2 20kA I_N is available.

GENERAL

Description:	Parallel connected, transient voltage surge suppressor device utilizing both high-energy handling and sine-wave tracking circuitry (60kA per mode or 180 ka per phase - peak surge current) for virtual elimination of impulse and ring wave type transients.
Application:	Designed for use at ANSI/IEEE Categories C, B and A with susceptibility up to medium exposure levels. Designed to protect sensitive/critical loads fed from distribution panels, branch panels and/or individual equipment panels.
Warranty:	20 Years Unlimited Free Replacement
Product Qualifications:	Listed to UL1449 3rd Edition (Sept. 2009) by CSA, an NRTL, CSA MC#214804, UL1283 and CE Compliant, ISO 9001:2000, ANSI C62.72-2007

MECHANICAL

Enclosure:	High strength ABS Plastic, Nema 4 rated
Mounting:	2.54 cm conduit fitting (internally threaded) and external mounting feet.
Connection Method:	#10 stranded wire // 2.60 mm dia.
Shipping Weight:	≈6 lbs // 2.7 kg

ELECTRICAL

Circuit Design:	Parallel connected, internal thermal fusing, hybrid design incorporating discrete all mode protection (10 modes for 3 phase wye units*) and utilizing our encapsulated design to provide improved durability. All suppression circuits are encapsulated in our exclusive compound to assure long component life and complete protection from the environment and/or vibration.
Protection Modes:	Dedicated protection components and circuitry for each mode. Discrete L-N, L-L (Normal Mode), and Discrete L-G, N-G (Common Mode). 10 modes / 3 phase wye system.
Input Power Frequency:	50-60Hz
Options:	LA-STB = Type 2 20kA I_N Type 1 available – contact factory for proper model number.
Circuit Diagnostics:	Super Bright LED, 1 per phase, normally on. Dry relay contacts for remote monitoring.
Circuit Interrupt:	External and internal (see installation instructions for details).
Fusing:	Line level and component level thermal cutouts (see installation sheet for full details)



Because we are constantly seeking to improve our products, specifications are subject to change at any time.

© 2009 ECS International Inc. Specification Last Changed 09/09 LA-ST180.doc

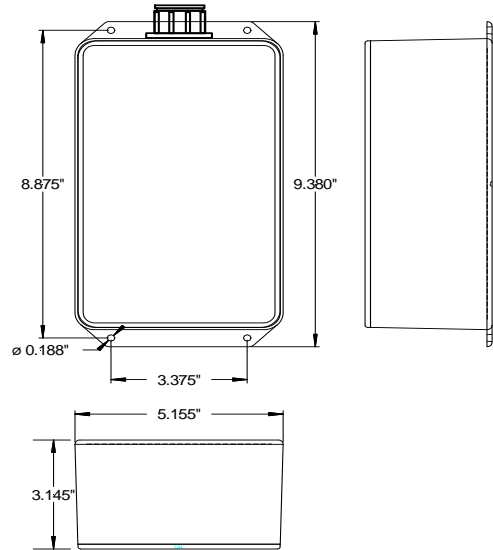

MEASURED LIMITING VOLTAGE PERFORMANCE AND ELECTRICAL SPECIFICATIONS

Model	Circuit Type	MCOV	Peak Surge Current (Amps) Per Mode	Mode	ANSI/IEEE C62.41 & C62.45 Let-Through Voltage Test Results		
					A1 2kV, 67A 100kHz Ring Wave 270° Phase Angle	ANSI/UL 1449- 2006 (Third Edition) Voltage Protection Rating (VPR)	C3 20kV, 10kA Impulse Wave 90° Phase Angle
LA-ST1801P1-CK	120V, Single Ø (2 wire + ground)	150 L-N 150 L-G 150 N-G	60,000 L-N 60,000 L-G 60,000 N-G 180,000 Total	L-N L-G N-G	45 60 55	500 500 500	914 1025 1176
LA-ST1801S1-CK	120/240V, Split Ø (3 wire + ground)	300 L-L 150 L-N 150 L-G 150 N-G	60,000 L-L 60,000 L-N 60,000 L-G 60,000 N-G 300,000 Total	L-L L-N L-G N-G	75 45 60 55	1000 500 500 500	1119 914 1025 1176
LA-ST1803Y1-KC	120/208V, 3ØY (4 wire + ground)	300 L-L 150 L-N 150 L-G 150 N-G	60,000 L-L 60,000 L-N 60,000 L-G 60,000 N-G 300,000 Total	L-L L-N L-G N-G	55 45 60 55	1000 500 500 500	1119 914 1025 1176
LA-ST1801P2-CK	240V, Single Ø (2 wire + ground)	320 L-N 320 L-G 320 N-G	60,000 L-N 60,000 L-G 60,000 N-G 180,000 Total	L-N L-G N-G	60 80 55	1000 1000 1000	1050 1262 1575
LA-ST1803Y2-CK	277/480V, 240/415V, 220/380V, 3ØY (4 wire + ground)	550 L-L 320 L-N 320 L-G 320 N-G	60,000 L-L 60,000 L-N 60,000 L-G 60,000 N-G 600,000 Total	L-L L-N L-G N-G	130 60 80 55	1800 1000 1000 1200	1344 1050 1262 1575
LA-ST1803N2-CK	240V, 3ØΔ (3 wire + ground)	320 L-L 320 L-G	60,000 L-L 60,000 L-G 360,000 Total	L-L L-G	95	1000 1000	1262 1262
LA-ST1803N4-CK	380V, 3ØΔ 480V, 3ØΔ (3 wire + ground)	550 L-L 550 L-G	60,000 L-L 60,000 L-G 360,000 Total	L-L L-G	140	1800 1800	1344 1344

Let-Through Voltage Test Environment: Positive Polarity. Time base=1ms. All voltages are peak (±10%). Surge voltages are measured from the insertion point of surge on the sine wave to the peak of the surge. All tests are Dynamic (voltage applied) except N-G which is static (no voltage applied). All tests were performed with 6 inches of lead length outside the device enclosure which simulates actual "as installed" performance.

Single-pulse, surge current capacities of 200,000 amps or less are determined by single-unit testing of all components within each mode. Present industry test equipment limitations require testing of individual components or sub-assemblies within a mode for single-pulse, surge current capacities over 200,000 amps.

Because we are constantly seeking to improve our products, specifications are subject to change at any time.

© 2009 ECS International Inc. Specification Last Changed 09/09 LA-ST180.doc